

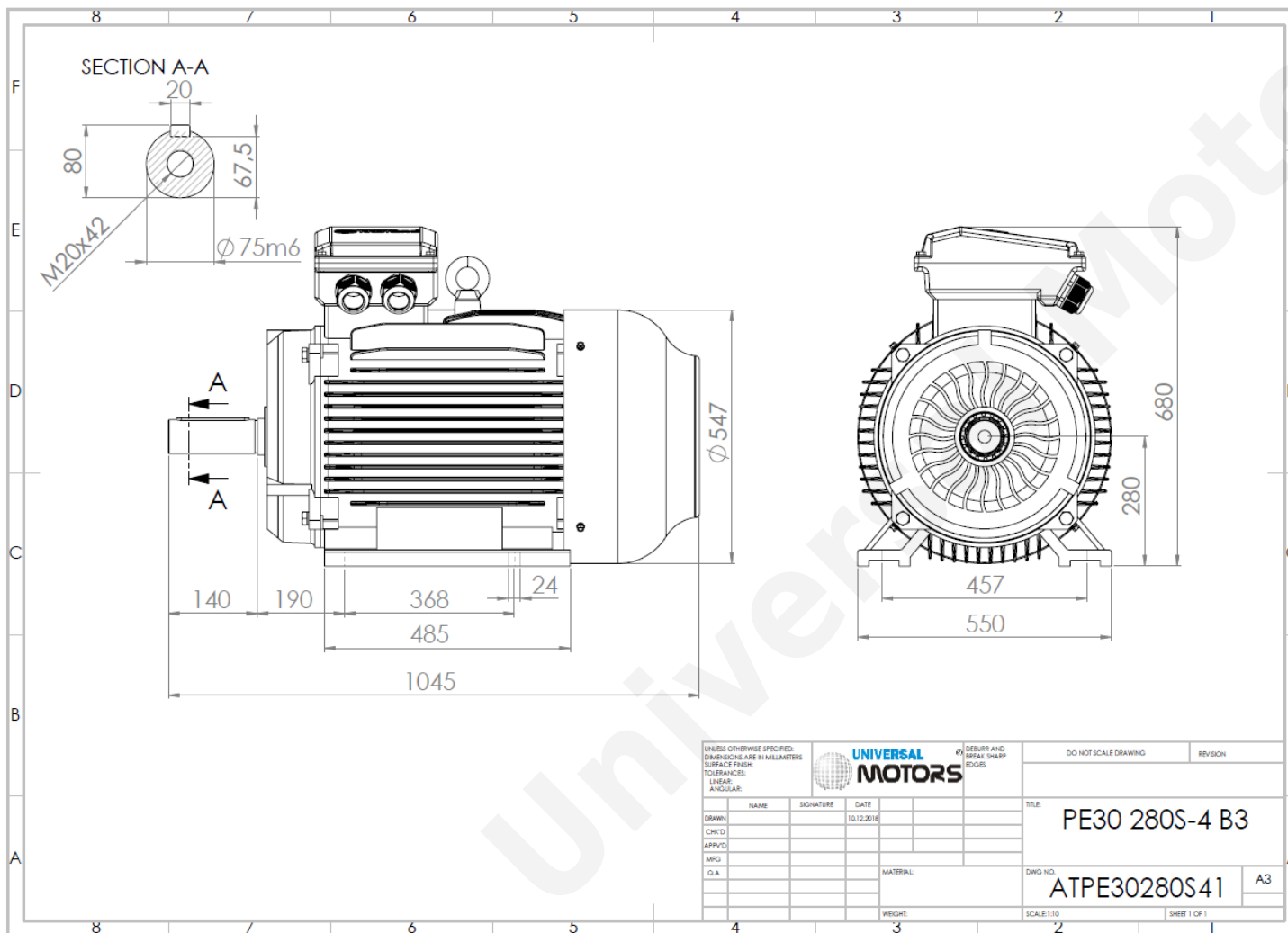

TECHNICAL DATA

Three Phase Electric Motors - Cast Iron Frame
 PE30 280 S 6 IE3
 45 kW / 60 Cv
 990 RPM



Motor type:	PE30 280 S 6 IE3
Output:	45 kW / 60 Cv
Speed (min^{-1}):	990 RPM
Frequency:	50 Hz
Voltage:	400 V
Current:	81.6 A
Power factor ($\text{Cos } \phi$):	0.85
Poles:	6
Insulation class:	F
Temperature rise Class:	B
Efficiency 50%:	92.9 %
Efficiency 75%:	93.7 %
Efficiency 100%:	93.8 %
Torque:	434 N.m
Tstarting/Tnominal:	2.0
Istarting/Inominal:	7.3
Tmaximum/Tnominal:	2.0
Noise:	67 Db(A)
Weight:	522 Kg
Bearing DE:	6317 C3
Bearing NDE:	6317 C3

Regime - S1

Altitude - 1000m

Environment Temperature - 40°C

CONTACTS:

UNIVERSAL MOTORS Tel: +351 252 299 080
 Rua de São Brás,745 Fax: +351 252 299 089
 4480-782 VILA DO CONDE Mail: geral@universalmotors.pt

* References applied only in the UK